



7.5t GVW ECO HYBRID 2014 MODEL YEAR

**CANTER
ECO HYBRID**



Exclusively from Mercedes-Benz

2014 MODEL YEAR

Eco Hybrid

7.5t GVW

4x2

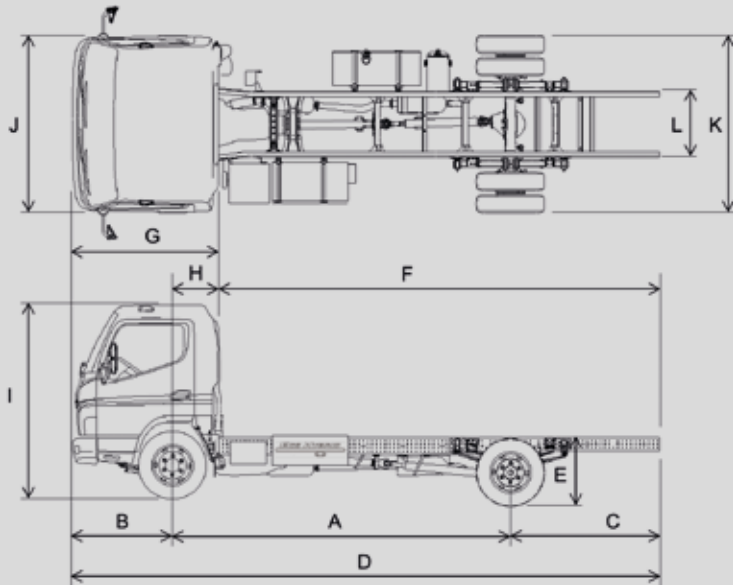

DIMENSIONS

		7C15	
A. Wheelbase	mm	3400	3850
B. Front Overhang	mm	1140	1140
C. Rear Overhang	mm	1395	1695
D. Overall Length	mm	5935	6685
E. Chassis Height (Chassis-Cab unladen)	mm	790	790
F. Back of Cab to End of Frame	mm	4270	5020
G. Bumper to Back of Cab	mm	1665	1665
H. Front Axle to Back of Cab	mm	525	525
I. Overall Height (Chassis-Cab unladen)	mm	2190	2190
J. Cab Width (excluding mirrors)	mm	1995	1995
K. Rear Axle Width (to tyre wall)	mm	2027	2027
L. Frame Width	mm	752	752
Cab to Body Gap (minimum)	mm	100	100
Maximum Possible Body Length	mm	4985	5725
Maximum Possible Body Width	mm	2550	2550
Turning Circle (kerb to kerb)	m	12.4	14.0
Turning Circle (wall to wall)	m	13.8	15.2

WEIGHTS

		7C15	
Chassis-Cab Weight Total	kg	2550	2570
Chassis-Cab Weight Front Axle	kg	1680	1690
Chassis-Cab Weight Rear Axle	kg	870	880
Front Axle Capacity	kg	3100	3100
Rear Axle Capacity	kg	6000	6000
Maximum Gross Vehicle Weight (GVW)	kg	7500	7500
Maximum Gross Train Weight (GTW)	kg	11000	11000
Body and Payload Allowance	kg	4950	4930

Weights and Dimensions are for guidance only – For Body-Building calculations refer to the Canter Body/Equipment directives available from the FUSO Body-Builder portal
 Manufacturing tolerance for Chassis Height and Overall Height is ± 25 mm
 Manufacturing tolerance for Chassis-Cab weights is $\pm 5\%$
 Chassis-Cab weights include 20 litres of fuel, 12 litres of AdBlue® and exclude the driver
 Maximum Possible Body Length dimension is with 65% overhang. Rear overhang must be extended to achieve this. Front Axle loading must be a minimum of 25% of GVW
 Maximum Possible Body Width dimension is valid only with additional side indicators and mirrors set to the 'outside set' position

ENGINE

Engine Power / Torque Curves

4P10-AAT4

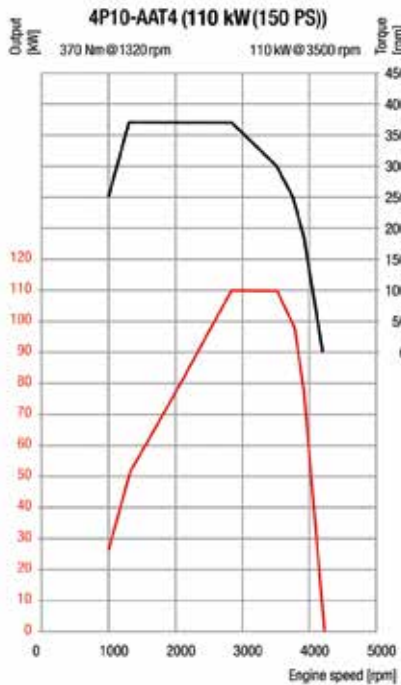

Diesel Engine	
Type	Diesel, 4-stroke, 4-Cyl, 2998cm ³ , 16-valve, DOHC, VGT Turbo, Intercooled, common-rail direct-injection
Emissions Level	Euro VI (heavy-duty)
Emissions Treatment	EGR + DPF + SCR (BlueTec)
Air Intake Type	High cab mounted Intake, paper element type, restriction indicator
Max. Power Output (EEC)	kW 110
	PS 150
	rpm 3500
Peak Torque (EEC)	Nm 370
	rpm 1320
Fuel Type	Diesel (to EN 590 standard)
NOx reduction agent	AdBlue® (to ISO 22241 standard)
Idle start/stop system (ISS)	Standard on all models. Over-ride switch in cab
Diesel engine mounted Alternator	AC 12V 140 Amp

Hybrid Electric Vehicle (HEV) system	
Description of system	Electric motor drive system combines with the Diesel Engine to provide Hybrid drive. Battery charging is via generator during regenerative braking. System comprises of Electric Motor/Generator, High Voltage Battery, Power Controller and connecting harnesses
Hybrid System type	Parallel P2
Driver interface	System performance/status monitor integrated into the multi-function dashboard display
Electric Motor/Generator	
Model	Mitsubishi Heavy Industries S20
Type	AC Permanent magnet synchronous motor, 3 phase
Maximum Power output	40 kW
Maximum Torque output	200 Nm
Location on vehicle	Integrated into the DUONIC® transmission housing
Cooling media	Oil
Battery	
Type	Lithium ion pouch
Energy	7.5 Ah
No. of Cells	72
Operating voltage	270 V (Nominal)
Cooling Media	Air
Power Controller	
Type	EPF2-3
Cooling media	Water/Glycol coolant mix

TRANSMISSION, AXLES, WHEELS AND TYRES



Clutch Designation	Maintenance Free, Automated Dual Clutch, Wet type – multi disc without torque loss					
Gearbox Designation	M038S6 (DUONIC® AMT)					
Gearbox Description	Dual Clutch 6-speed, Automated with Creep, Park and Manual functions with integrated HEV motor/generator					
Gear Ratios	1st / Reverse	2nd	3rd	4th	5th	6th
	5.397	3.788	2.310	1.474	1.000	0.701
Rear Axle Ratio	4.875					
Wheel/Tyre Arrangement	Front axle: Single, Rear axle: Dual					
Wheels	17.5 x 6.00 - 127 - 9t - 6 stud					
Tyres	205 / 75 R 17.5 124 / 122 M					

PERFORMANCE		
Maximum Speed – Limited	km/h (mph)	90 (56)
Maximum Speed – Unlimited	km/h (mph)	130 (81)
Maximum Gradeability @7.5t	% (theoretical)	29.5

CHASSIS

Frame Section	mm	Inside wheelbase: 192 x 60 x 6 (+ reinforcement) Tank capacity Diesel / AdBlue®
	MPa	Material Yield Strength: 305 MPa
Tank Capacity Diesel / AdBlue®	Litres	100 / 12
Electrical System / Batteries	12 Volt / 2 x 12 Volt (100AH-760A(EN)) connected in parallel	
Body Builder interfaces:	12V Body Builder electrical interface: 1 in cab and 1 rear of cab	
Trailer Electrics	13 Pin (12V) connector – pre-installed at rear of chassis	
Reverse Warning Buzzer	Standard fit without isolation switch (isolation switch can be added by dealer)	



SUSPENSION, STEERING AND BRAKES

Suspension Front	Semi-elliptic laminated leaf springs with double acting shock absorbers and stabiliser bar	
Suspension Rear	Semi-elliptic laminated leaf springs with double acting shock absorbers and stabiliser bar	
Steering	Power steering with recirculating ball and nut, tilt and telescopic column with steering lock	
Braking System	Service	Hydraulic, vacuum assisted, 2 circuit, ventilated disc brakes (Ø310mm) with ABS, EBD and over-ride feature
	Parking	Mechanical, internal expanding type mounted on the rear end of the transmission case
	Retarder	Electronically governed exhaust brake combined with HEV Generator – up to 50kW braking power



CAB FEATURES



EXTERIOR

- High strength steel welded cab
- Cab structure reinforced to meet the FUSO RISE (Realised Impact Safety Evolution) requirements
- Internal strength reinforcement beams built into doors
- Wide opening doors with deep side windows for enhanced lateral visibility
- Cathodic dip painted cab structure
- Cab entry / step illumination lamps built into door panel
- Heated foldable multi-adjusting rear-view mirrors
- Manual tilting mechanism for easy access to engine bay
- Single rear facing window in back wall of cab
- Extensive range of colours including Metallic and Pearl options
- 3 piece front bumper

INTERIOR

- Walk-through access
- 3 seat cab (driver + 2 passengers)
- Driver's suspension seat with adjustable springing rate, lumbar support and arm rest
- Isringhausen cloth seats (leather sides) with headrests
- Split folding passenger seat with access to clipboard and document tray
- Flame resistant interior materials
- 3-point seat belt on driver's seat and outboard passenger seat, lap belt for centre passenger
- Adjustable steering wheel (reach and rake)
- Grab Handles
- Vinyl floor covering
- Overhead storage shelves
- Locking glove box
- Storage area between seats
- Storage pocket on rear wall of cab
- Electric driver's side and passenger side windows
- Retractable twin cup holders
- 12V power socket
- Central courtesy light
- Tinted glass

SECURITY

- Engine Immobiliser
- Keyless remote central locking

INSTRUMENTS AND CONTROLS

- Multi-function electronic display screen (fuel consumption, trip, DPF status, time, HEV status, Gear indicator, Odometer, Maintenance info)
- Speedo in mph (and km/h)
- Fuel Gauge
- Rev counter with economy band
- Idle start/stop (ISS) disable switch
- Manual DPF regeneration switch
- Heater Mirror switch
- Fog lamp switch
- Electric window switches in door panels
- Wipers and Exhaust Brake control stalk
- Lighting and Indicator control stalk
- Rotary heater controls
- Steering wheel mounted horn switch
- Interior lamp switch on head lining
- Digital Tachograph (2 man)

OPTIONAL EQUIPMENT

- Electronic Stability Program (ESP)
- Limited slip differential
- Airbag driver's seat
- Airbag driver and co-driver seat
- Fully automatic air conditioning
- 24V Body-Builder interface (with 24V 80A Alternator)
- Additional 70 litre fuel tank (3850 wheelbase only)
- Pre installation for engine driven accessory
- Remote engine speed control for PTO
- PTO (196Nm) for direct connected ISO pumps
- PTO (196Nm) with flange
- Fire extinguisher 2kg (mounted inside cab)
- Spare Wheel/Tyre
- Michelin tyres
- Traction tyres
- Rear Underrun bar
- Rear Underrun with coupling provision
- Speed Limiter removed (Emergency vehicles only)
- Tachograph removed (out-of-scope vehicles only)
- Radio / CD / MP3 + Bluetooth®
- Selection of cab colours – ex-factory

WARRANTY AND MAINTENANCE

Standard Warranty	3 years / unlimited mileage
High Voltage Battery + Battery Control Unit Warranty	10 years / unlimited mileage
Standard Maintenance intervals	40,000 km / 1 year



SYSTEM	APPROVAL LEVEL
EC Type Approval	2007/46*1230/2012
Noise levels	Reg. 51 - 02
Engine power	Reg. 85 - 00
Emissions	595/2009*64/2012A
Fuel tanks	Reg. 34 - 02
Steering	Reg. 79 - 01
Door latches and hinges	130/2012
Vehicle Access	Reg. 11 - 03
Horn	Reg. 28 - 00
Indirect vision (mirrors)	Reg. 46 - 02
Braking	Reg. 13 - 11
EMC	Reg. 10 - 04
Diesel smoke	Reg. 24 - 03
Anti-theft / immobiliser	Reg. 116 - 00
Seat strength	Reg. 17 - 08
Seat belt anchorages	Reg. 14 - 07
Seat belts / restraints	Reg. 16 - 06
Electric Power Train	Reg. 100 - 01

SYSTEM	APPROVAL LEVEL
Head restraints	Reg. 25 - 04
Towing hooks	1005/2010
Id of Controls	Reg. 121 - 00
Cab heating	Reg. 122 - 00
Speedo / reverse gear	Reg. 39 - 00
Plates (statutory)	19/2011*249/2012
Lighting	Reg. 48 - 04
Spray-suppression	109/2011
Safety glazing	Reg. 43 - 00
Tyres	458/2011
Speed limitation devices	Reg. 89 - 00
Front underrun protection	Reg. 93 - 00
Masses and dimensions	1230/2012
External projections of cabs	Reg. 61 - 00
Cab Strength	Reg. 29 - 02
Rear Underrun bar (Option)	Reg. 58 - 02
Coupling Provision (Option)	Reg. 55 - 01



ALSO AVAILABLE:

CANTER 3.5T MANUAL / CANTER 3.5T DUONIC® / CANTER 7.5T DUONIC® / CANTER 7.5T MANUAL
/ CANTER 8.55T DUONIC® / CANTER 4X4 – 6C18 / CANTER CREW CAB

ISSUED BY MERCEDES-BENZ UK LTD,
TONGWELL, MILTON KEYNES, MK15 8BA

TELEPHONE: 0800 055 6050 (OR IF YOUR MOBILE PHONE PROVIDER CHARGES FOR FREEPHONE NUMBERS, 0333 222 0525)
WWW.CANTER.CO.UK

BODY-BUILDER INFORMATION AVAILABLE AT: [HTTP://BB-PORTAL.FUSO-TRUCKS.COM](http://bb-portal.fuso-trucks.com)

THE CONTENTS OF THIS BROCHURE ARE NOT BINDING AND THE RIGHT IS RESERVED TO MAKE MODIFICATIONS WITHOUT NOTICE.
DUONIC® IS A REGISTERED TRADEMARK OF DAIMLER AG



Exclusively from Mercedes-Benz